

# CHM 4220 Organic Synthesis, Dr. Laurie S. Starkey, Spring 2020, Final Exam

"I pledge to work alone on this exam and to not assist others. I will use only the approved resources: two pages of hand-written notes (front and back).

I pledge to maintain the confidentiality of this exam. I will not share the contents of this exam with anyone or with online sites. I understand that if any of the exam questions appear online, those exam questions will be deleted."

Name: \_\_\_\_\_ Signature: \_\_\_\_\_ Date: \_\_\_\_\_

**PERIODIC TABLE OF THE ELEMENTS**

p 1	30		p 4	40	
p 2	40		p 5	30	
p 3	40		p 6	20	
		Total	200		

1. (20 pts) Provide the missing reagents or structures (A–G) for each step of the following syntheses. Some transformations may require two steps.

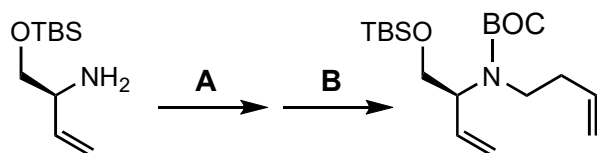

Grubbs I catalyst

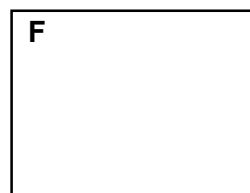
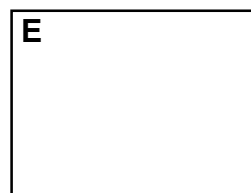
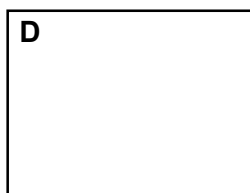
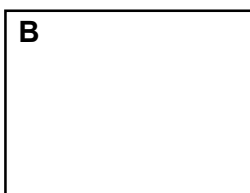
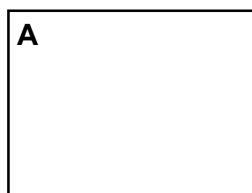
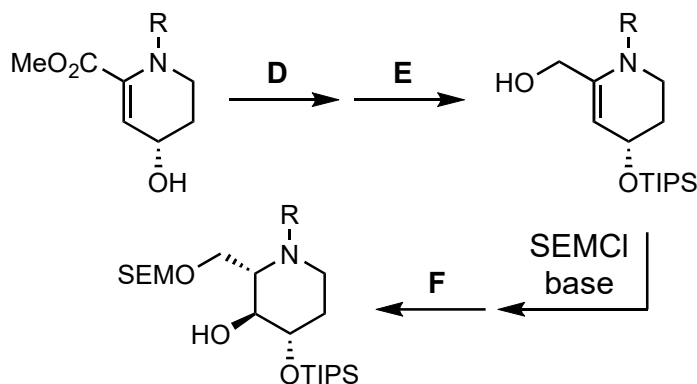

2. (10 points) Shown below is a step in a catalytic cycle involving a rhodium complex. Determine the oxidation state of rhodium in each complex (**show your work**), and describe the mechanism.

What is this type of mechanism called? \_\_\_\_\_

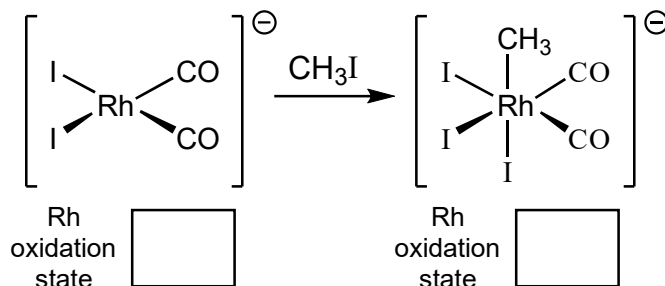

3. (80 pts) Provide the reagents necessary to transform the given starting material into the desired product. **Show your work, and draw at least one intermediate structure in each synthesis.** It may help to do a retrosynthesis first.

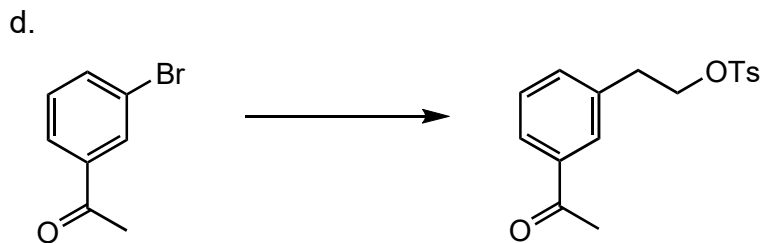
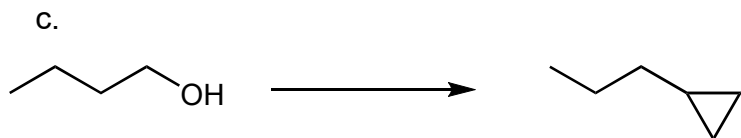
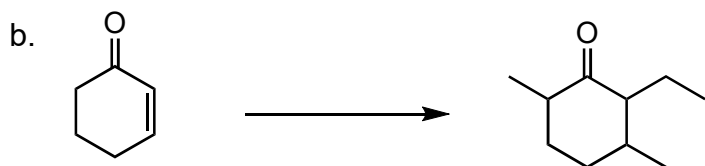
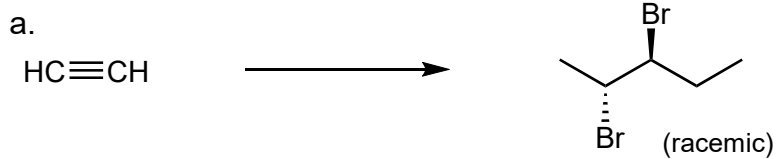

3. (cont'd) Provide the reagents necessary to transform the given starting material into the desired product. **Show your work, and draw at least one intermediate structure in each synthesis.** It may help to do a retrosynthesis first.

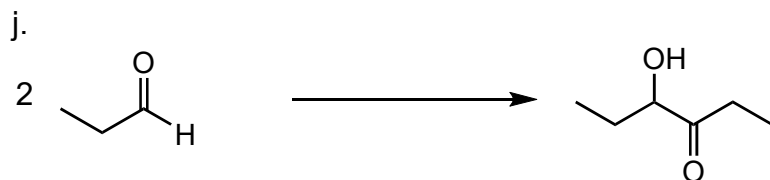
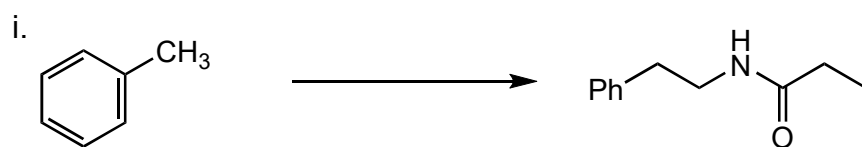
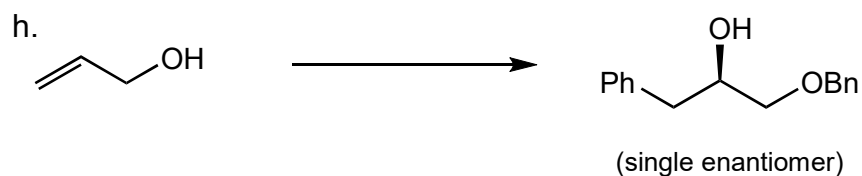
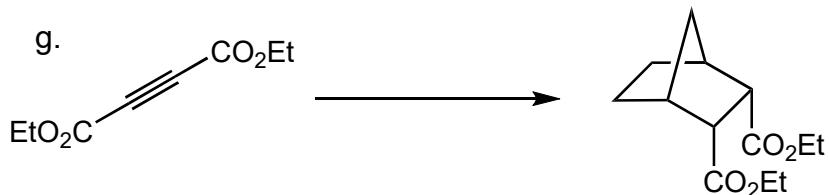
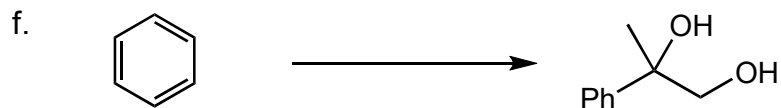

4. (40 pts) Synthesize the following target molecules. **Each synthesis must form at least one new C–C bond.** You may use any commercially available starting materials, reagents.

a.

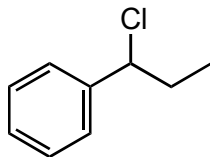

(from benzene and alcohols as only sources of carbon)

b.

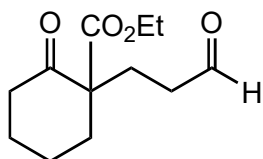

(from starting materials containing no more than **6** carbons)

c.

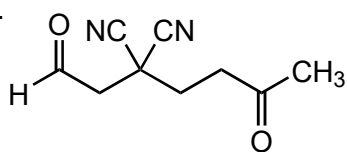

d.

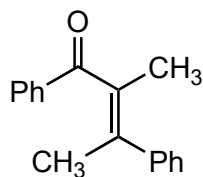

5. (10 pts) Provide a synthesis for the following target molecules (TM) that correctly incorporates the  $^{14}\text{C}$ -labeled (\*) carbon atoms as shown, using the given starting materials as the only sources of **labeled** carbon. Any commercially available reagents may also be used.

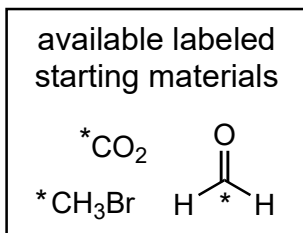
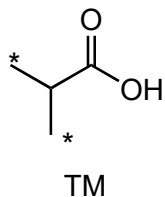

6. (10 pts) Predict the possible **monochlorination** products, including all possible regioisomers and stereoisomers. Indicate if any of the products are expected to be formed in equal amounts.

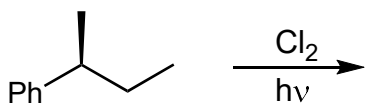

7. (10 pts) Predict the major products of the given transformation.

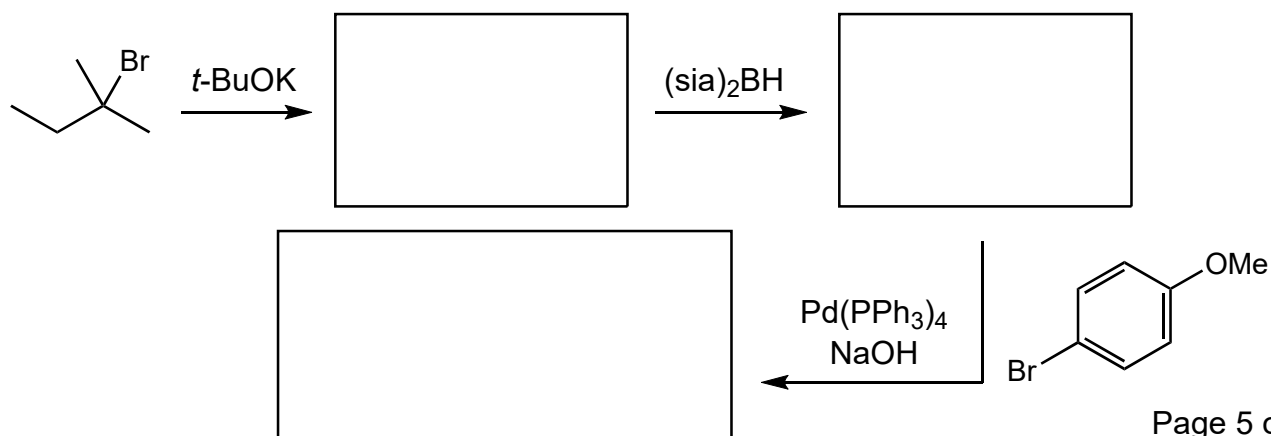

8. (8 pts) Explain briefly why the following attempted synthesis of the given target molecule fails, and provide a different synthetic sequence that would accomplish the transformation shown.

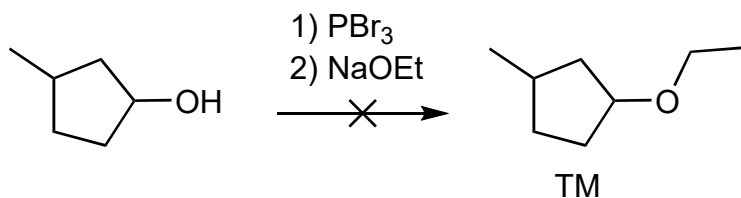

Explain briefly why it failed:

9. (6 pts) What is the relationship between  $\text{H}_a$  and  $\text{H}_b$  (homotopic, enantiotopic, or diastereotopic)?  
**Show your work.**

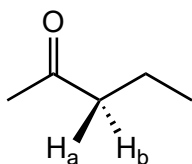

Is  $\text{H}_b$  pro-*R* or pro-*S*?

**Show your work.**

10. (6 pts) Predict the major product and be sure to show relevant stereochemistry.

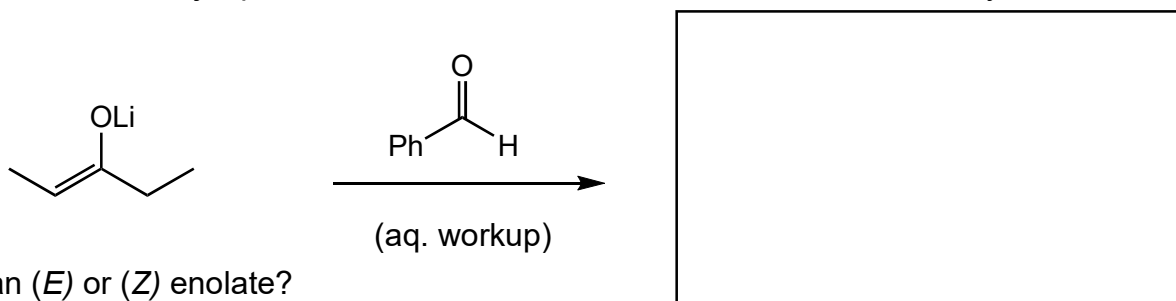

Is this an (*E*) or (*Z*) enolate?  
Explain briefly.